

# Setup Guide for

# **mimio**<sup>®</sup>



## Board



**For Windows 98SE/Me/2000/XP/Vista  
& Mac OS X 10.3.9 or later**

Use this to quickly setup and use your mimio Board or mimio Board HD.

# Accessory Box Contents

---



**mimio Mouse** - Ergonomic stylus with left-click, right-click, and hover functions.



**Wireless Receiver** - Plugs into any available USB port, provides a wireless link to your mimio Board.



**USB Cable** - 16ft (5m) USB cable to connect your mimio Board to your computer.



**USB Extension Cable** - Extension cable for the wireless USB Receiver, for computers with very close USB ports.



**AC Adapter** - Provides persistent power for your Wireless mimio Board.



**mimio Studio CD** - Advanced user friendly interactive application suite.



**AA Battery** - Battery included for your mimio Mouse stylus.

# System Requirements

---



## Microsoft Windows

- IBM compatible, Pentium 166 MHz minimum
- Windows 98SE/Me/2000/XP/Vista
- 32 MB RAM minimum (64 MB RAM recommended)
- 30 MB free disk space minimum
- CD-ROM Drive
- Available USB port



## Mac OS X

- 400 MHz processor (800 MHz or faster recommended)
- Mac OS X version 10.3.9 or higher
- 128 MB RAM minimum (256 MB RAM recommended)
- 30 MB free disk space minimum
- CD-ROM Drive
- Available USB port

1



Install the mimio software from CD if not already installed. Check our website for the latest mimio software ([www.mimio.com](http://www.mimio.com)).

2



Plug the Wireless Receiver into an available USB port. If there is insufficient space to fit the Wireless Receiver into a USB port, the included USB Extension cable can be used with the Wireless receiver to allow for the USB connection.

3

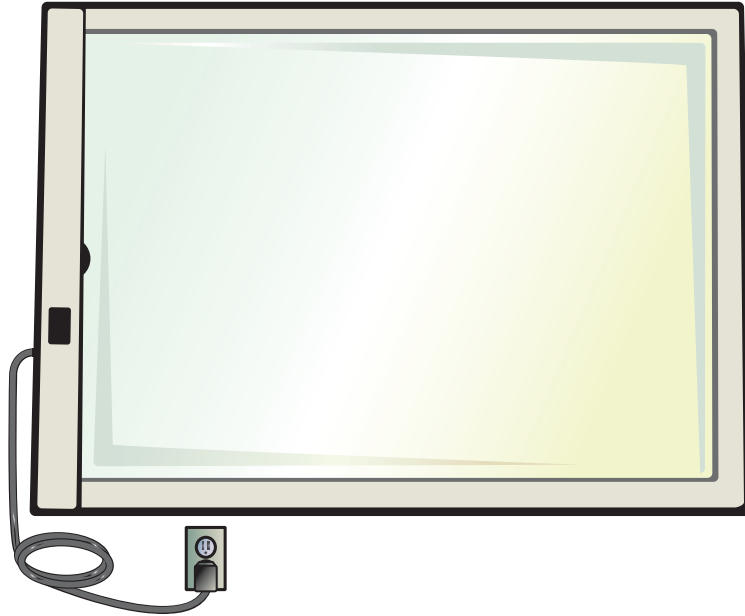

Power on mimio Board using the included AC Adapter.

4

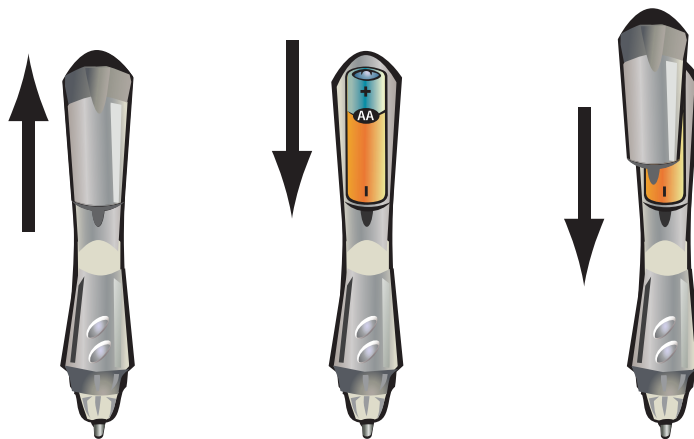

Install AA battery into the mimio Mouse stylus.

## Setup Process continued

5



Project desktop image onto mimio Board surface. Make sure there is a 2-3" buffer between the left edge of the projected image and the left edge of the mimio Board.

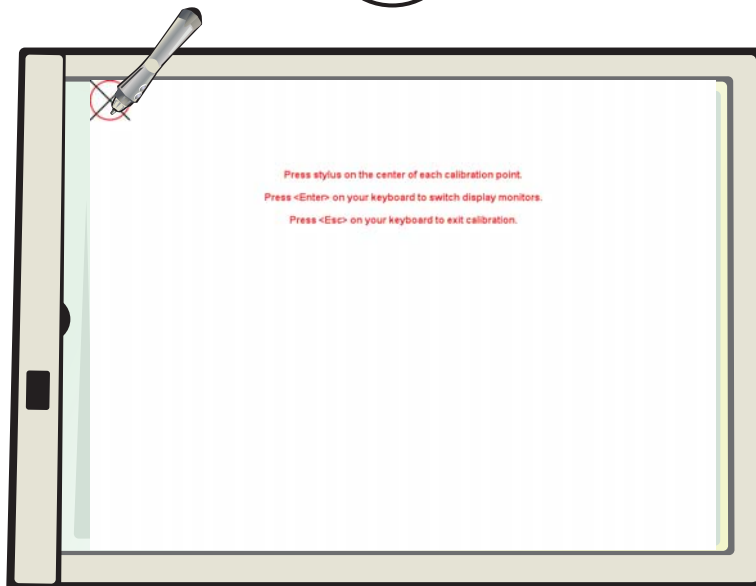

6



Press the interactive button  on the mimio Board to begin the calibration routine. Follow onscreen instructions.

## Using the Interactive Mode

---

- Use the mimio Mouse stylus as a mouse to control your desktop or to interact with applications.
- Press the Hover (front) button on the mimio Mouse stylus to hover the mimio Mouse over your Desktop or application.
- Press the Right-Click (back) button on the mimio Mouse stylus to execute a right-click at the current mimio Mouse location.
- Use the floating mimio Tools to annotate on top of any application. Follow steps below:
  1. Click on the Screen Markup  button to “freeze” the projected image for annotation.
  2. Use the various drawing tools on the Draw tab of the mimio Tools to annotate the projected image.
  3. Click on the Mouse  button to “unfreeze” the projected image and to automatically save the annotated image for later retrieval from the Markups tab on the mimio Tools.
- Use the mimio Notebook application to create and present content.

For more information about using your mimio Board interactively, please check out the comprehensive mimio Studio User’s Guide on the mimio Studio CD.

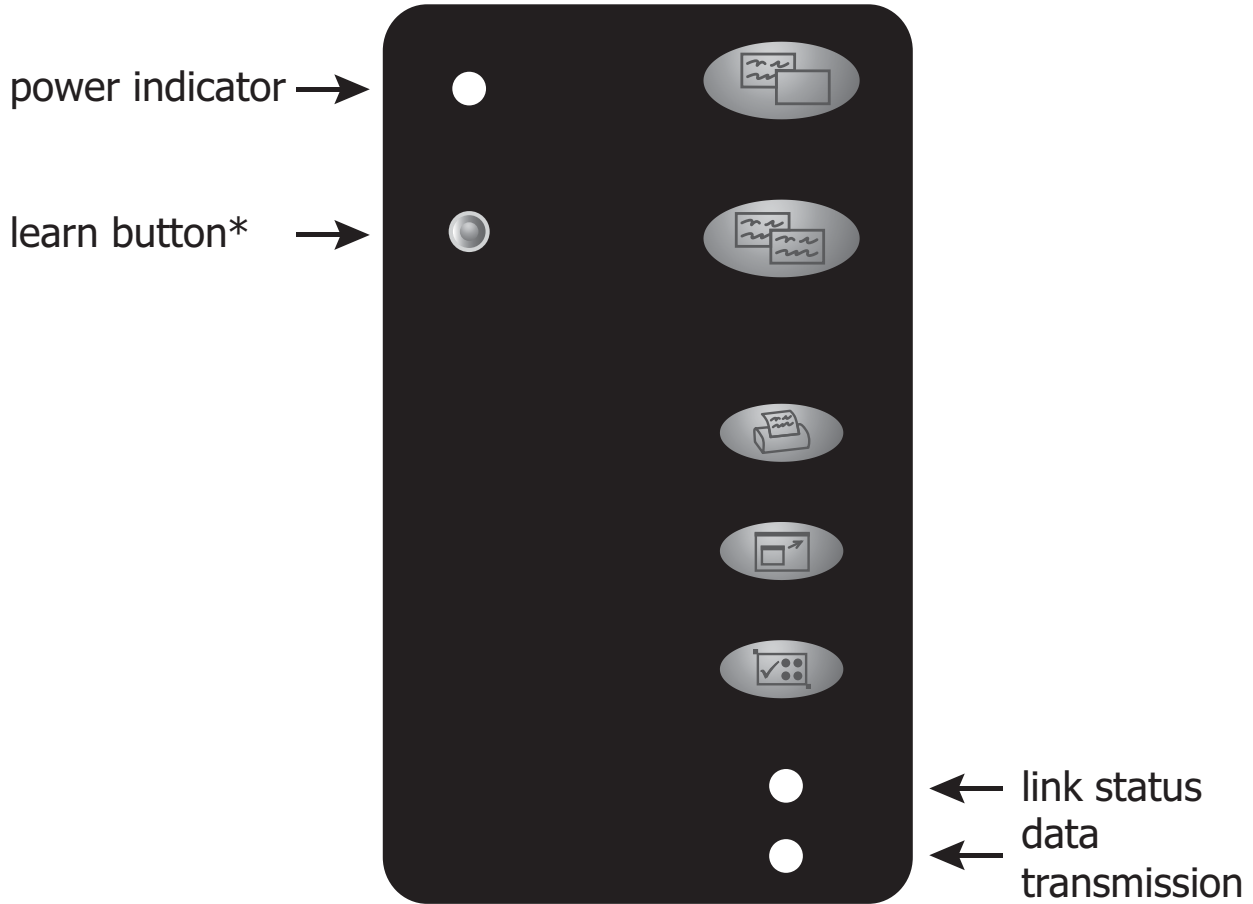

## Link Status Indicator

**Green:** A wireless link is established between the mimio Board and the computer.

**Amber:** There is no wireless link between the mimio Board and the computer. Refer to the Troubleshooting Section.

**Flashing green:** mimio Board is in Learning Process\*.

## Data Transmission Indicator

**Slow flashing green:** System is idle.

**Fast flashing green:** mimio stylus pen is in use.

**Off:** No data is being communicated between the mimio Board and the computer. Refer to Troubleshooting Section.

\* Refer to the Learning Section for more information.

# Wall Mounting Instructions

---

**READ INSTRUCTIONS COMPLETELY BEFORE INSTALLING.**

It is important that walls or plaster be completely dry before installing a board, as any moisture may cause the panel inserts to warp.

Complete hanging hardware is included with each unit. If wall construction prevents the use of hardware as furnished, it is the responsibility of the customer to furnish the required fasteners.

## **REFER TO WALL MOUNTING DIAGRAM ON PAGE 8**

- 1) Locate wall studs on which to attach mounting rail. Determine desired mounting height, measuring from the floor to the top of the unit. Snap a chalkline along the wall at the desired location for the top edge of the Crest-Line unit.
- 2) Mark the hole locations along the mounting rail (long leg up) to correspond with stud locations in the wall. NOTE: Minimum hole locations is 6" in from each end of the mounting rail and at approximately 24" spacing along the length of the mounting rail). Drill 13/64" holes at each location marked on the mounting rail.
- 3) Align mounting rail (long leg up) along chalkline and mark on the wall the location of the holes drilled into the mounting rail. At each hole location marked on the wall, drill 1/4" holes 1" deep for expansion plugs.
- 4) Install the mounting rail with the long leg up. It may be necessary to shim out the mounting rail on uneven or irregular walls.
- 5) Subtract 1-1/4" from overall height measurement of unit being installed. Using this figure, measure down from top of mounting rail. Install L-Clip screw at this point. Leave L-Clip in down position. L-Clips should be installed 6" in from each bottom corner and evenly space along length of board.
- 6) Hang unit on mounting rail. Make any slight adjustment to desired position by sliding to left or right. Be sure unit is hanging level.
- 7) Tap L-Clips up against bottom of the unit and drill holes into aluminum trim (holes must be smaller than diameter of screws). Fasten clip to trim with screw furnished.

# Wall Mounting Instructions continued

---

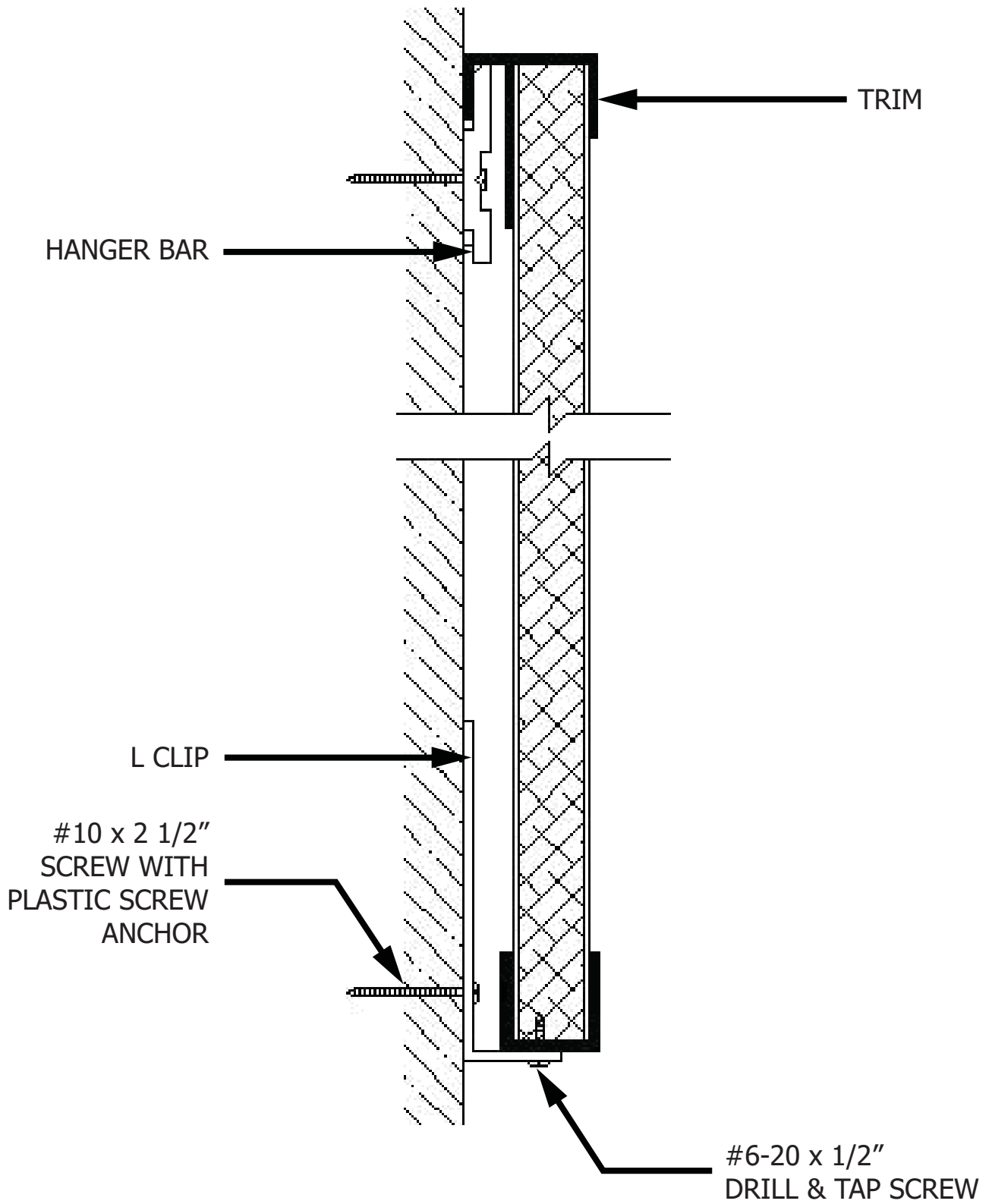

# Floor Stand Assembly Instructions (optional)

**READ INSTRUCTIONS COMPLETELY BEFORE ASSEMBLING.**

\* Verify all floor stand parts listed below are included in the box.



Top crossbeam with pre-installed board mount brace



Bottom Crossbeam

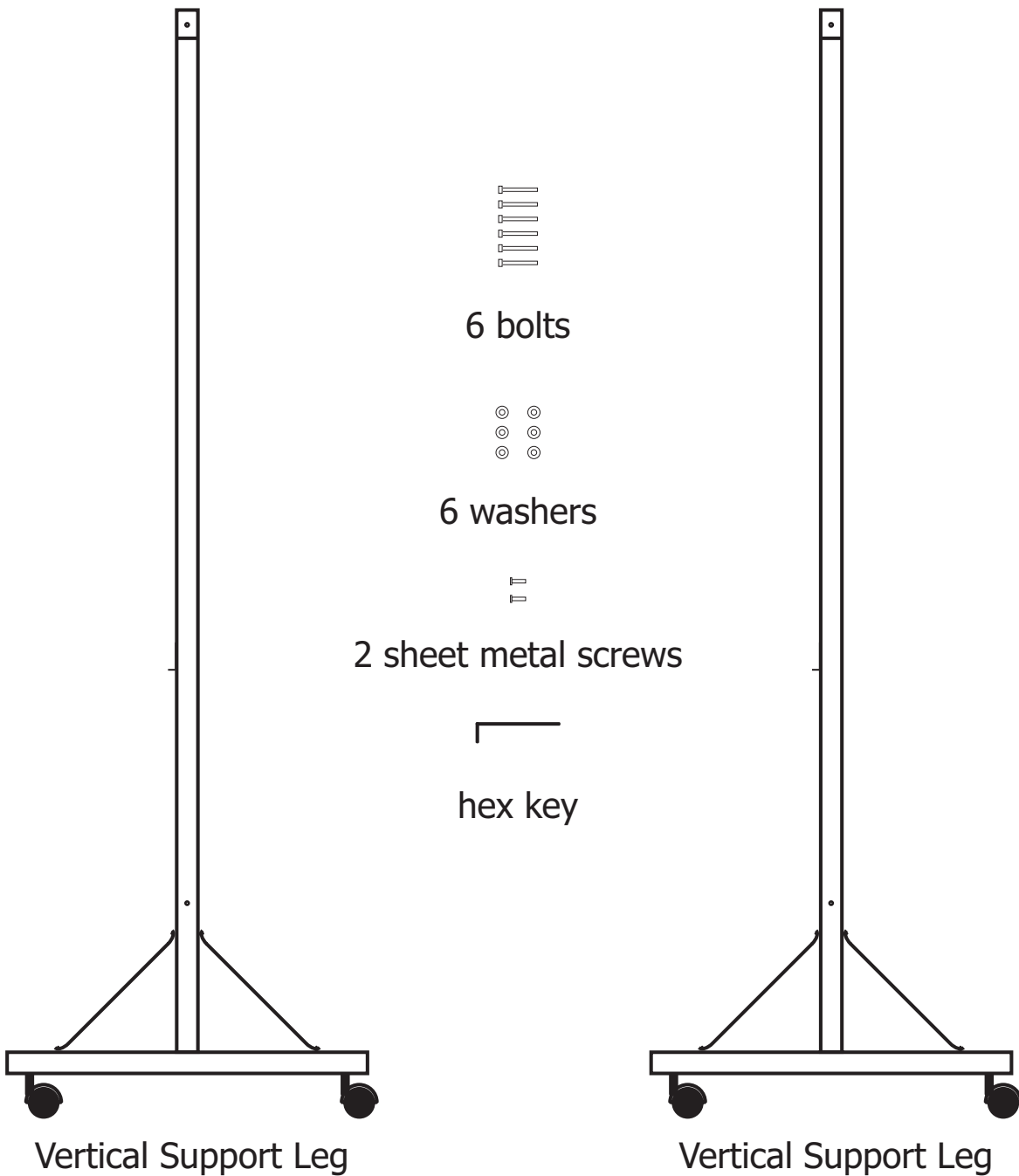

6 bolts



6 washers



2 sheet metal screws



hex key

Vertical Support Leg

Vertical Support Leg

## Floor Stand Assembly Instructions continued

### WARNING!

The mimio Board is a highly durable porcelain steel whiteboard. As a result of its construction, it is a very heavy product, weighing in excess of 70 lbs. For safety reasons, assembly of the mimio Board product and its floor stand requires the assistance of at least 2 adults.

Please be sure to follow the assembly instructions. Upon completion, please check and verify that all bolts are appropriately positioned and tightened.

1

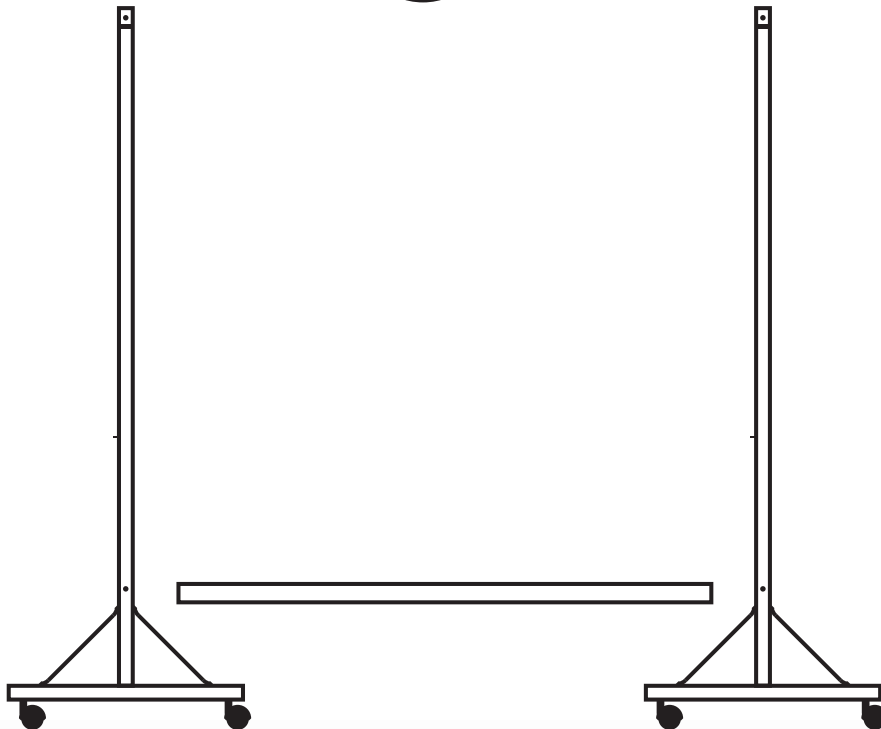

Lie the 2 vertical support legs flat onto the floor with the bottom crossbeam positioned between the 2 support legs in preparation for assembly. Use the hex key to secure the bottom crossbeam to the 2 vertical support legs using 2 of the bolts and 2 of the washers.

## Floor Stand Assembly Instructions continued

---

2

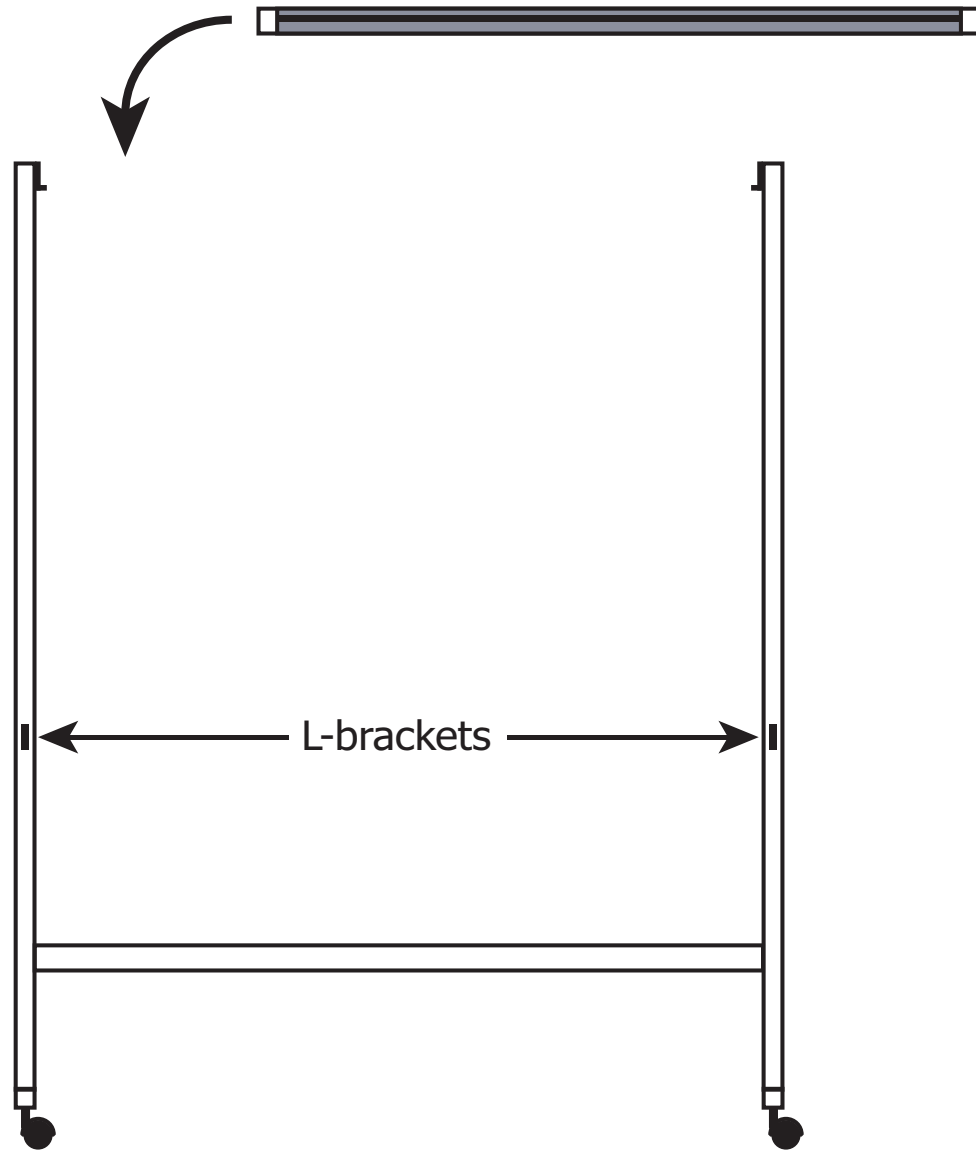

Position the partially assembled floor stand upright. Use the hex key and 2 of the bolts and 2 of the washers to assemble the top crossbeam to the floor stand. Be sure to orient the top crossbeam such that the mimio Board mounting bracket faces in the same direction as the 2 L-brackets and the label on the top crossbeam marking TOP correctly points up.

3

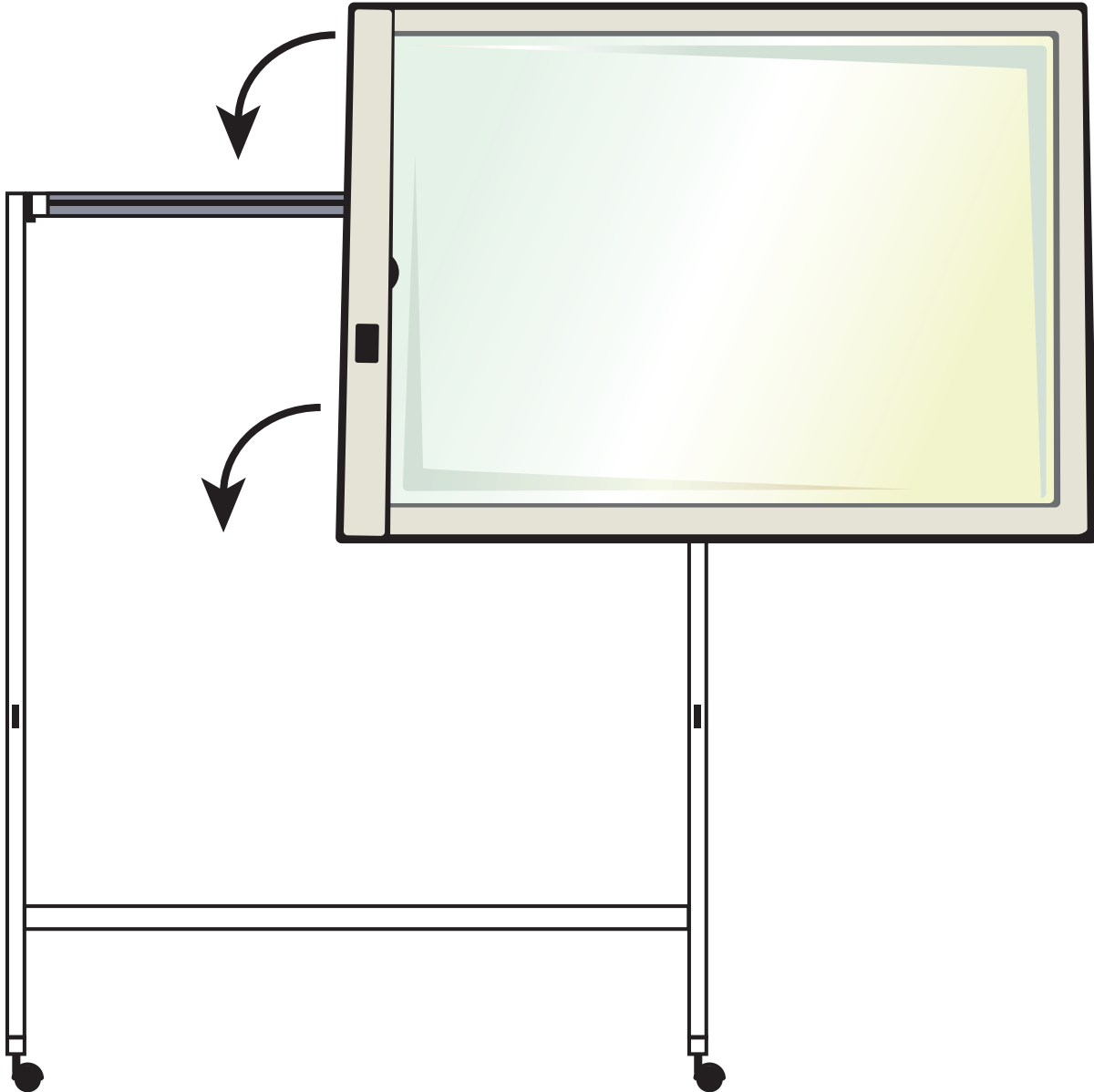

Attach mimio Board to assembled floor stand. Align the mounting brace on the backside of the mimio Board with the mounting brace on the top crossbeam of the floor stand. Use the 2 sheet metal screws to Secure the 2 L-brackets to the bottom edge of the bottom mimio Board framing. The sheet metal screws are self-tapping and will screw directly into the aluminum framing.

## Learning Process

---

The mimio Board and Wireless Receiver are programmed at the factory and are packaged as a mated pair to work “out of the box” without user intervention\*. They are an exclusive pair of components that will only communicate to one another. This allows for more than one Wireless mimio device to co-exist in the same environment without causing confusion over which Wireless mimio device communicates to which mimio Wireless Receiver.

Since the mimio Board and Wireless Receiver are designed to work exclusively as a pair, you cannot casually interchange a Wireless Receiver from one Wireless mimio device with a Wireless Receiver from another Wireless mimio device and expect it to work; mixed components will not be able to communicate unless they have been programmed as a pair. A mimio Board can only be paired with one mimio Wireless Receiver at any given point in time; you cannot program one mimio Board to work with multiple Wireless Receivers and vice versa.

### **Mating the mimio Board and Wireless Receiver:**

If you own multiple Wireless mimio devices and mistakenly get the Wireless Receiver components mixed together, you can manually re-program any mimio Board and Wireless Receiver components to work exclusively together through a learning process. The learning process is described in the steps listed below.

1. Power on the mimio Board.
2. Plug the Wireless Receiver into an available USB port on your computer.
3. Press and hold the teach button on the Wireless Receiver for 3 seconds to initiate the learning process (the LED on the Wireless Receiver should begin flashing green).
4. Press the recessed learn button on the mimio Board with the end of a paper clip to complete the learning process. A beep will sound when learning process begins.
5. The Link Status LED will start flashing green while the learning process is underway. Once the mimio Board and Wireless Receiver are mated, the Link Status LED will turn to a solid green color to identify the 2 components have been paired and that a wireless connection is established.

---

\* 802.11x and/or Bluetooth is neither required nor supported.

## Troubleshooting

---

If the Link Status LED on the mimio Board is amber, a wireless connection cannot be made between the mimio Board and the Wireless Receiver. Please try the following steps to establish a wireless connection between these two mimio Wireless components:

1. Ensure the computer is powered and turned on.
2. Ensure the Wireless Receiver is plugged into an available USB port on your computer.
3. Ensure the mimio Board is powered with its AC power adapter and has a solid green power LED.
4. Move the computer closer to the mimio Board.

If you still cannot establish a wireless connection after following the steps listed above, try unplugging the Wireless Receiver from the computer and then reinserting the Wireless Receiver into the computer. If this does not help, then follow the steps outlined in the Learning Process section to re-bind the mimio Board and Wireless Receiver. If completing the Learning Process does not result in a wireless connection, please contact our Technical Support department using one of the contact methods described in the Technical Support section.

# Technical Support

---

All mimio products include free phone and e-mail support.

Email: [techsupport@mimio.com](mailto:techsupport@mimio.com) (United States and Canada) or [techsupport.europe@mimio.com](mailto:techsupport.europe@mimio.com) (Europe)

Telephone: 1-877-846-3721 (United States and Canada) or +44 870 458 3366 (Europe)

Web Site: <http://www.mimio.com/support>

With all support inquiries, please provide us with the following information:

- mimio Board model number (located on the regulatory label)
- mimio software version number
- Operating system on computer
- Make and model of computer
- Description of problem

This device complies with Part 15 of the FCC Rules. Operation is subject to the following two conditions:

(1) this device may not cause harmful interference.

(2) this device must accept any interference received, including interference that may cause undesired operation.

This equipment has been tested and found to comply with the limits for a Class B digital device, pursuant to Part 15 of the FCC Rules. These limits are designed to provide reasonable protection against harmful interference in a residential installation. This equipment generates, uses and can radiate radio frequency energy and, if not installed and used in accordance with the instructions, may cause harmful interference to radio communications. However, there is no guarantee that interference will not occur in a particular installation. If this equipment does cause harmful interference to radio or television reception, which can be determined by turning the equipment off and on, the user is encouraged to try to correct the interference by one or more of the following measures:

- Reorient or relocate the receiving antenna.
- Increase the separation between the equipment and receiver.
- Connect the equipment into an outlet on a circuit different from that to which the receiver is connected.
- Consult the dealer or an experienced radio/TV technician for help.

Caution: Changes or modifications not expressly approved by the party responsible for compliance could void the user's authority to operate the equipment. Contact mimio, 25 First Street - Suite 301, Cambridge, MA 02141. Technical Support: 877-846-3721.

**mimio** - A *NewellRubbermaid* Company

---

25 First Street - Suite 301  
Cambridge, MA 02141

Toll-free in US: (877) my-mimio (696-4646)  
Main telephone: (617) 902-2040  
Fax: (617) 902-2041  
E-mail: [productinfo@mimio.com](mailto:productinfo@mimio.com)

---

7 Berkshire Business Centre  
Berkshire Drive  
Thatcham, Berkshire  
RG19 4EW  
UK

Telephone: +44 870 458 3344  
Fax: +44 870 458 3355  
Support: +44 870 458 3366  
E-mail: [eurosales@mimio.com](mailto:eurosales@mimio.com)

© 2007 Sanford LP. All rights reserved. mimio is a registered trademark and mimio Board is a trademark of Sanford LP.

Windows is a registered trademark of Microsoft, Inc. Mac OS is a registered trademark of Apple Computer, Inc. All rights reserved.